

SCHMEISER®

BANTAM LEVELER

ASSEMBLY & PARTS MANUAL



T. G. SCHMEISER CO., INC.

P.O. BOX 1047 FRESNO, CA 93714-1047

(559) 268-8128 FAX (559) 268-3279

www.tgschmeiser.com

VERSION 2.0

7 - 2007

INTRODUCTION

Your Schmeiser Bantam Leveler is designed to give you many years of dependable service. This manual has been prepared to instruct you in the safe and efficient operation of this machine. Read and study it thoroughly. Follow all instructions carefully.

Should your Bantam Leveler require replacement parts, go to your Schmeiser dealer. Always order genuine Schmeiser replacement parts.

It is important that you complete and send in your Warranty Card because it is not valid unless it is on file at Schmeiser. If you need information not contained in this manual, contact your Schmeiser dealer.

Space has been provided below for you to record the model number and serial number of your Bantam Leveler. Be sure to bring this information with you to your dealer when ordering parts for your Bantam Leveler.

Thank you for buying a Schmeiser Bantam Leveler.

SERIAL NUMBER _____

MODEL NUMBER _____

DATE PURCHASED _____

DEALER NAME _____

TABLE OF CONTENTS

Introduction	2
Table of Contents.....	3
Safety Sheet.....	4
Bantam Leveler Assembly Instructions.....	5
Bantam Leveler Complete Assembly.....	6
Wheel Axle Bearing Assembly.....	8
Bucket Crank Assembly.....	9
Bantam Leveler Wheel Axle Assembly.....	10
Bantam Leveler Hydraulic Diagram.....	11
Limited Warranty.....	12

SAFETY

The safe operation of any machinery is an important concern to farmers and manufactures. There are obvious and hidden potential hazards involved in the operation of this implement. Carefully read and follow all safety precautions before operation. Serious injury or death may occur unless care is taken to insure the safety of both the operator and any other persons in the area.

1. Never permit anyone to ride on or walk beside the implement when moving.
2. Never permit anyone to ride on tractor when implement is being moved.
3. When performing operating functions, never allow anyone to be near the implement or the tractor.
4. Do not enter tractor when tractor is moving. Avoid serious injury or death from contact with rotating tires. Enter and exit the tractor only when it is completely stopped.
5. Be sure of water, gas, sewer, or electric line locations before operating implement.
6. When in transport, use accessory lights and devices for adequate warning to operators of other vehicles. Comply with all Federal, State and local laws when traveling on public roads.
7. Use "Slow Moving Vehicle" emblem for warning vehicles approaching from the rear.
8. When transporting, remember that the implement may be wider than your tractor and extreme care must be taken to allow for safe clearance.
9. Never allow inexperienced or untrained personnel to operate the implement or tractor without supervision.
10. When using compressed air to clean implement, wear safety glasses.
11. Check all fasteners for tightness or damage before and after operation. Repair immediately if required.
12. Store implement in a stable position. Insure that safety stands are extended and locked in place before detaching from tractor.



1. Locate wheel axle and mount tires to wheel axle.
2. Suspend main frame over wheel axle, mount wheel axle to main frame with bearing assemblies (see Bearing Assembly drawing for details). Tighten.
3. Mount 4" x 16" Hydraulic Cylinder with rod facing rear of unit to main frame and axle cylinder anchor bottom hole using (2) 1" x 3-1/2" cylinder pins with hair pin clips.
4. Secure wheel axle with lockout bar. Install yellow 1" x 2-1/2" pin with 5/16" cotter pin to the main frame side, red 1" x 2-1/2" pin with 1/4" lynch pin – to axle's cylinder anchor top hole.
USE CONNECTION TO CYLINDER ANCHOR FOR TRANSPORTATION ONLY!
5. Move main frame over bucket. Connect bucket arms to main frame with 3/4" x 4" bolts and nylon lock hex nuts. Tighten, but bolts must be able to rotate.
6. Mount left crank arm bar to left adjustment plate with 3/4" x 2-1/2" bolts with lock washers and hex nuts. Repeat for right handed side.
7. Mount bucket cranks to main frame crank angle bracket using (4) 5/8" x 2" bolts with lock washers and hex nuts. Tighten securely.
8. Install trunnion nuts in trunnion clevises on the bucket. Make sure that zerk fittings are facing inside for easier lubrication.
9. Lift up bucket from center to insert threaded parts of cranks into trunnions. Screw in both sides evenly.
10. Position roller to rear of unit and connect to main frame mounting angles with (8) 3/4" x 2" bolts, lock washers, and hex nuts.
11. Insert tongue between top and bottom tongue plates on the main frame. Secure with (2) 7/8" x 6-1/2" bolts with double hex nuts. Install bolts upside down.
12. Install hose holder (pig tail) to tongue with (1) 1/2" x 1-1/2" bolt with lock washer and hex nut.
13. Install jack stand.
14. Connect hoses to the hydraulic cylinder. Secure to hose holder.

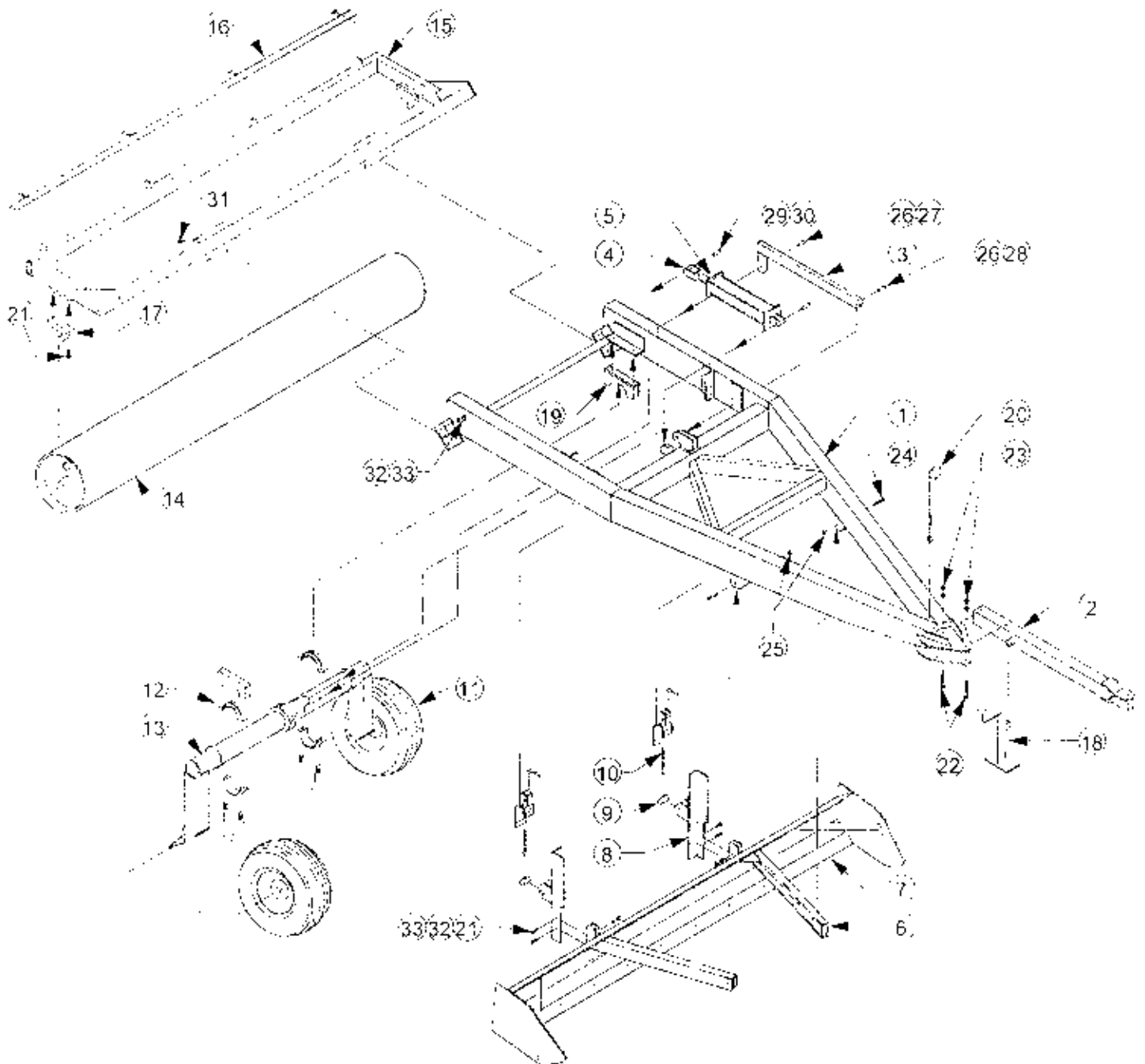



<u>Ref No.</u>	<u>Part No.</u>	<u>Description</u>	<u>Qty.</u>
1.	SBL-00B00	Bantam Leveler Main Frame Weldment	1
2.	SBL-00A000	Bantam Leveler Tongue Weldment	1
3.	SBL-00J000	BL Hydraulic Cylinder Lockout Weldment	1
4.	GHC-40160T	4" X 16" Tie Rod Hydraulic Cylinder	1
5.	PMCK-34000	Seal Kit for 4" x 16" Tie Rod Hydraulic Cylinder	1
6.	SBL-(00)C100	BL Bucket Weldment (specify size)	1
7.	SBL1608 through SBL1618	BL Bucket Blade Kit (8ft. - 18ft. Units)	1
8.	SBL-00C300L(R)	BL Bucket Crank Arm LH and RH	2
9.	SLL1525L(R)	Bucket Screw Assembly LH and RH	2
10.	SLL1526	Bucket Crank Rod Nut (ACME Thread)	2
11.	GWT-761508	7.60 X 15 Tire with Wheel	2
12.	SLL1353	Wheel Axle Bearing Assembly	2
13.	SBL-00E000	BL Wheel Axle Weldment	1
14.	SBL-(00)G000	BL Roller Weldment	1
15.	SBL-(00)F000	BL Roller Frame Weldment	1
16.	SBL-(00)H000	BL Roller Scraper Weldment	1
17.	TPP3150	1-11/16" Pillow Block Bearing (9 ft. to 15 ft. Units)	2
	TPP3157	1-15/16" Pillow Block Bearing (16 ft and up Units)	2
18.	GJK-2KTW10	Jack Stand	1
19.	SLL1351	1" Bearing Cradle Weldment	2
20.	GHD-HHOLD1	Hose Holder	1
21.	CSNC512040	3/4" X 2-1/2" Gr.5 NC Cap Screw	4
22.	CSNC514104	7/8" X 6-1/2" Gr.5 NC Cap Screw	2
23.	HXNUT-14NC	7/8" NC Hex Nut	4
24.	CSNC512064	3/4" X 4" Gr.5 NC Cap Screw	2
25.	HYNUT-12NC	3/4" Nylon Lock Hex Nut	2
26.	GPN-16X040	1" X 2-1/2" Clevis Pin Weldment	2
27.	GPN-040LYN	1/4" Lynch Pin	1
28.	GPN-05X40C	5/16" Cotter Pin	1
29.	GPN-1656HC	1" X 3-1/2" Cylinder Pin	2
30.	GPN-03CLIP	5/32" Hair Pin Clip	2
31.	CSNC512032	3/4" X 2" Gr.5 NC Cap Screw	8
32.	LWASHER-12	3/4" Lock Washer	12
33.	HXNUT-12NC	3/4" NC Hex Nut	12



WHEEL AXLE BEARING ASSEMBLY

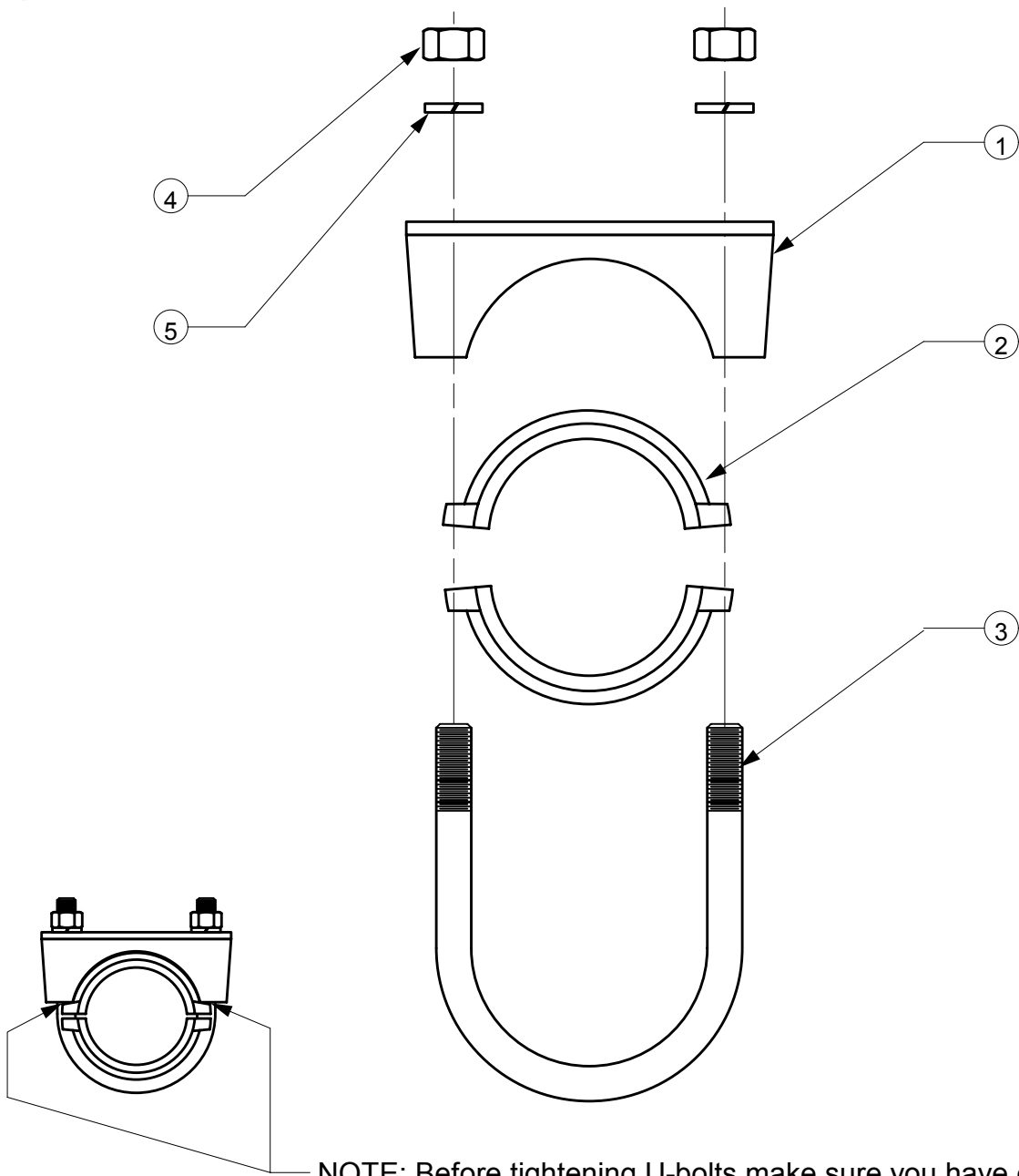

NOTE: Before tightening U-bolts make sure you have equal amount of space on each side.

<u>Ref No.</u>	<u>Part No.</u>	<u>Description</u>	<u>Qty.</u>
1.	SLL 1351	Bearing Cradle Cap Weldment	4
2.	SLL 1350	Bearing Cap Casting Machined	8
3.	UBNC16122R	1" Bearing U-bolt	4
4.	HXNUT-16NC	1" NC Hex Nut	8
5.	LWASHER-16	1" Lock Washer	8
	SLL 1352	U-Bolt Assembly (includes items 3, 4, and 5)	
	SLL 1353	Axle Bearing Assembly (includes items 1, 2, 3, 4, and 5)	

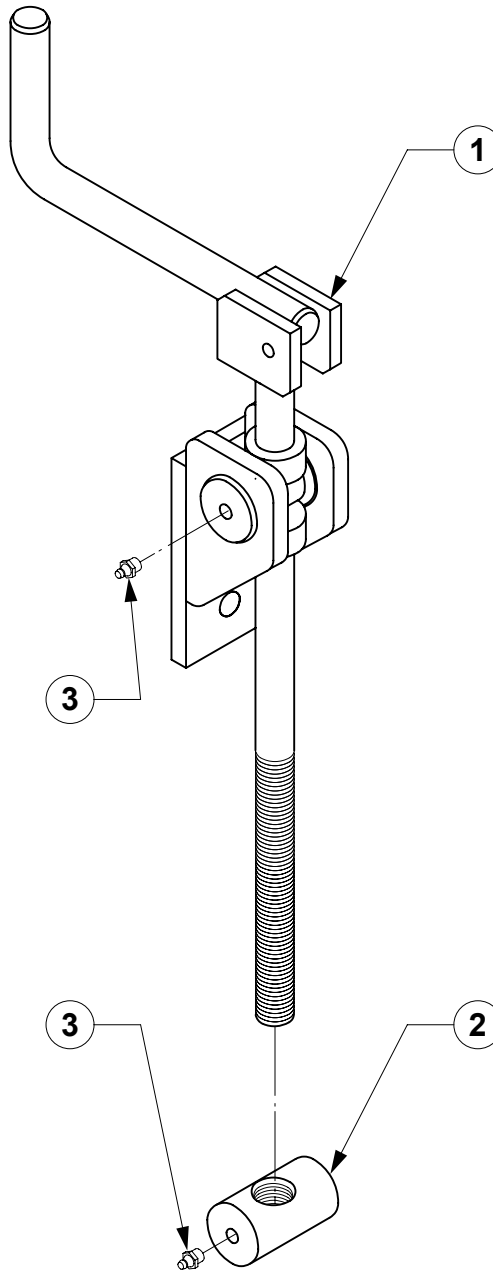

<u>Ref No.</u>	<u>Part No.</u>	<u>Description</u>	<u>Qty./ Unit</u>
1.	SLL1525L	Bucket Crank Assembly LH	1
	SLL1525R	Bucket Crank Assembly RH	1
2.	SLL1526	Bucket Crank Rod Nut ACME Thread	2
3.	GMB-ZERKDT	Drive Type Zerk Fitting	4



BANTAM LEVELER WHEEL AXLE ASSEMBLY

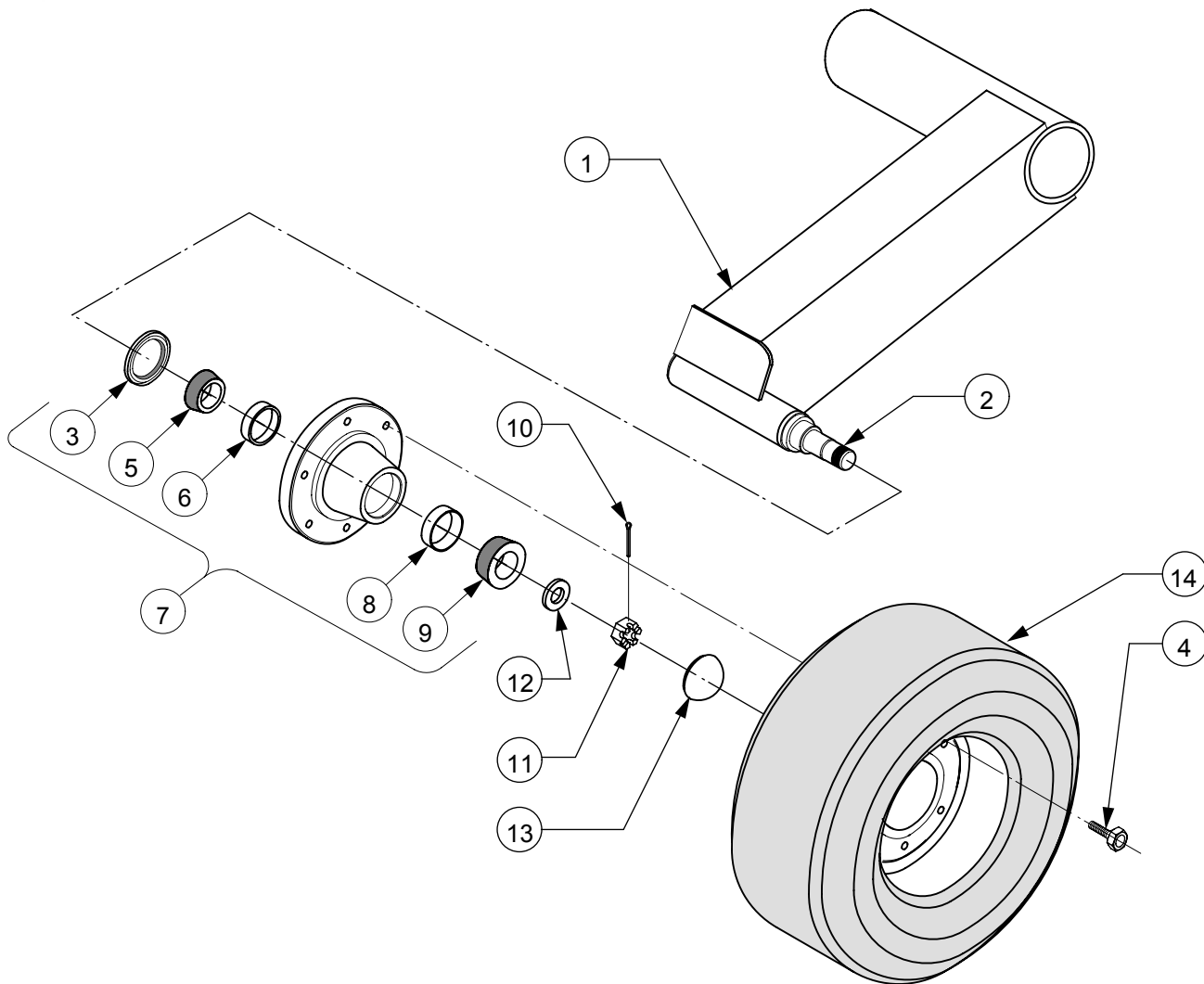

<u>Ref No.</u>	<u>Part No.</u>	<u>Description</u>	<u>Qty.</u>
1.	SBL-00E000	Bantam Leveler Wheel Axle Weldment	1
2.	GSP-32176S	2" x 11" Single Ended Spindle	2
3.	GHB-6X6GSL	Grease Seal	2
4.	WHB-08X016	1/2" x 1" UNF Wheel Bolts for 6 on 6 Std. Hub	12
5.	GHB-6X6ICN	Inner Bearing Cone for 6 on 6 Std. Hub	2
6.	GHB-6X6IRC	Inner Bearing Cup for 6 on 6 Std. Hub	2
7.	GHB-6X6STD	Standard 6 on 6 Hub Assembly Complete (includes items 3, 4, 5, 6, 8, 9, 13)	2
8.	GHB-6X6ORC	Outer Bearing Cup for 6 on 6 Std. Hub	2
9.	GHB-6X6OCN	Outer Bearing Cone for 6 on 6 Std. Hub	2
10.	GSP-14SPWA	Spindle Washer	2
11.	GSP-14CANT	Spindle Castle Nut	2
12.	GPN-03X32C	3/16" x 2" Cotter Pin	2
13.	GHB-6X6CAP	Hub Cap	2
14.	GWT-761508	7.6 x 15 8 Ply Tire with Wheel	2

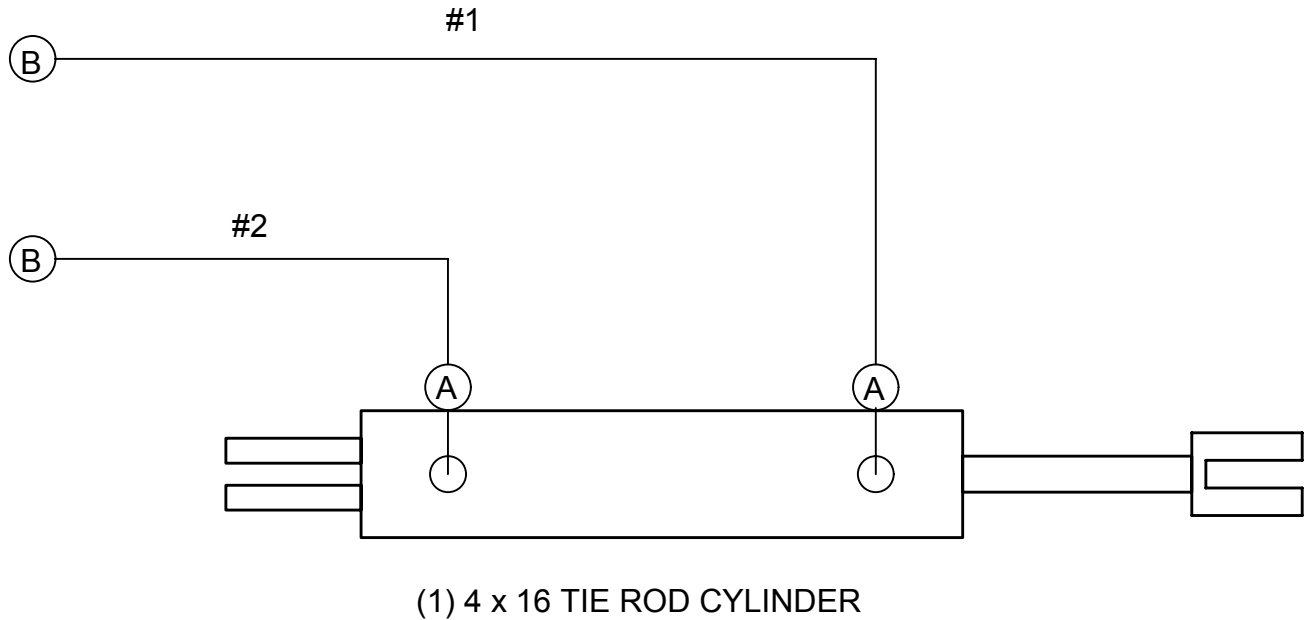

NOTE: ALL FITTINGS ARE 3000 P.S.I. CAP
ALL HOSES ARE 1/2" Ø

HYDRAULIC CYLINDER:			
	<u>Part No.</u>	<u>Description</u>	<u>Q-ty</u>
	GHC-40160T	4" X 16" Tie Rod Cylinder	1
FITTINGS:			
<u>Ref No.</u>	<u>Part No.</u>	<u>Description</u>	<u>Q-ty</u>
A	FMBFBX9088	MB-FBX 90° 8-8 Fitting	2
B	PIPE08PLUG	8FB Hydraulic Pipe Plug	2
HOSES:			
<u>Ref No.</u>	<u>Part No.</u>	<u>Description</u>	<u>Q-ty</u>
#1	FMBFBX9088	8MP-8MP 208" Long	1
#2	PIPE08PLUG	8MP-8MP 188" Long	1
	HKBL	Hose Kit for Bantam Leveler (includes both hoses)	

T.G. SCHMEISER CO., INC.®

Limited Warranty Statement

T. G. Schmeiser Co., Inc. warrants each new Schmeiser® product to be free from defects in material and workmanship. This warranty is applicable only for the normal service life expectancy of the product or components, not to exceed twelve (12) consecutive months from the date of delivery of the new Schmeiser product to the original purchaser.

Genuine T. G. Schmeiser Co., Inc. replacement parts and components will be warranted for 90 days from date of purchase, or the remainder of the original equipment warranty period, whichever is longer.

Under no circumstances will it cover any merchandise or components thereof, which, in the opinion of the company, has been subjected to misuse, unauthorized modifications, alteration, an accident or if repairs have been made with parts other than those obtainable through T. G. Schmeiser Co., Inc.

The Company in no way warrants engines, batteries, cylinders, tires or other trade accessories since these items are warranted separately by their respective manufacturer. Expendable components such as points, shanks, blades, rings, bearings, teeth, and the like are excluded from this warranty.

Our obligation under this warranty shall be limited to repairing or replacing, free of charge to the original purchaser, any part that, in our judgment, shall show evidence of such defect, provided further that such part shall be returned within thirty (30) days from date of failure to T. G. Schmeiser Co., Inc., routed through the dealer and distributor from whom the purchase was made, transportation charges prepaid.

This warranty shall not be interpreted to render T. G. Schmeiser Co., Inc. liable for injury or damages of any kind or nature to person or property. This warranty does not extend to the loss of crops, loss because of delay in harvesting, or any expense or loss incurred for labor, substitute machinery, rental or for any other reason.

Except as set forth above, **T. G. Schmeiser Co., Inc. shall have no obligation or liability of any kind on account of any of its equipment and shall not be liable for special or consequential damages. T. G. Schmeiser Co., Inc. makes no other warranty, expressed or implied, and, specifically, T. G. Schmeiser Co., Inc. disclaims any implied warranty or merchantability or fitness for a particular purpose. Some states or provinces do not permit limitations or exclusions of implied warranties or incidental or consequential damages, so the limitations or exclusion in this warranty may not apply.**

This warranty is subject to any existing conditions of supply, which may directly affect our ability to obtain materials or manufacture replacement parts.

T. G. Schmeiser Co., Inc. reserves the right to make improvements in design or changes in specifications at any time, without incurring any obligation to owners of units previously sold.

No one is authorized to alter, modify or enlarge this warranty nor the exclusion, limitations and reservations.

**WARRANTY VOID IF NOT REGISTERED
WITHIN 30 DAYS OF PURCHASE DATE**